

Permitted material: Besides writing-equipment, up to two pieces of paper up to A4 size can be brought, with free choice of content: handwritten, printed; small, large; text, diagram, image; one or both sides, etc. These papers do not need to be handed in with the exam.

Unless it is stated otherwise, the final answer to a question should be expressed in terms of the known quantities given in the question, and any clear simplifications should be done. Component values such as R for a resistor, U for an independent voltage source, or K for a dependent source, are assumed to be known quantities. Marked currents or voltages such as i_x are assumed to be definitions, not known quantities.

Clearly drawn and labelled diagrams are a good way to help yourself avoid mistakes, and to make clear to others what you are doing. By showing clearly your intermediate steps in a solution, you improve your chance of getting points even if the final result is wrong. You may write in Swedish or English; but we suggest that writing in either is seldom necessary if you make good use of diagrams and equations!

KS2 does not give any direct grade. Its points will be used to replace Section-B in the final exam or re-exam, if this would improve your points there. See therefore the rules for the exam to relate the points to grades: at least 40% is needed in Section-B alone, as well as 50% overall.

Nathaniel Taylor (08 790 6222)

1) [5p] Find the:

a) [2p] Energy stored in C_1 at $t = 0^-$.

b) [2p] Power into R_2 at $t = 0^+$.

c) [1p] Power from source U as $t \rightarrow \infty$.

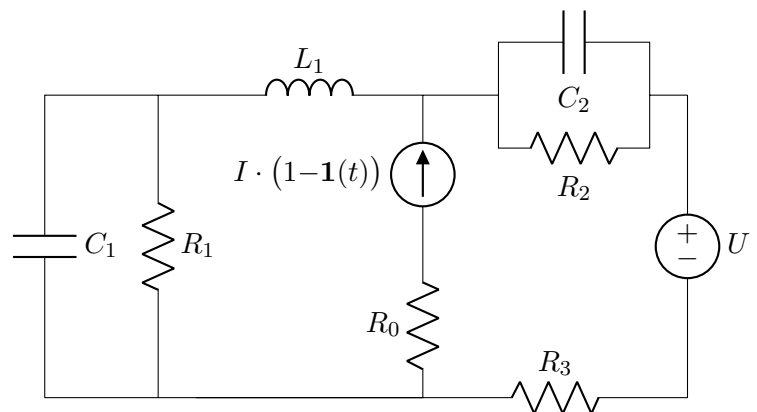

2) [5p]

Determine the marked current i , for $t > 0$.

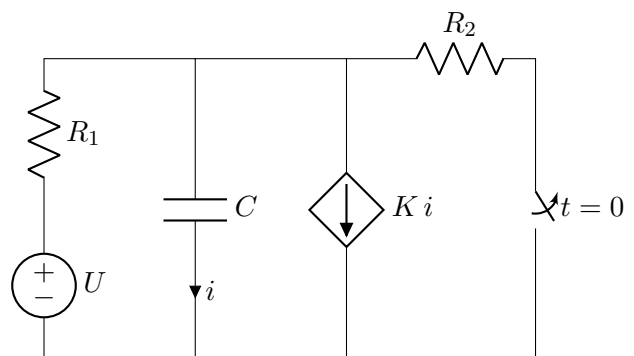

Översättningar:

Hjälpmedel: Upp till två A4-ark (båda sidor) med studentens egna anteckningar på valfritt sätt: handskrivet eller datorutskrift; text, diagram, bild; stor eller liten textstorlek, o.s.v. Dessa måste inte lämnas in med skrivningarna.

Om inte annan information anges i ett tal ska: komponenter antas vara ideala; angivna värden av komponenter (t.ex. R för ett motstånd, U för en spänningskälla, K för en beroende källa) antas vara *kända* storheter; och andra markerade storheter (t.ex. strömmen markerad i ett motstånd eller spänningskälla) antas vara *okända* storheter. Lösningar ska uttryckas i kända storheter och förenklas.

Var tydlig med diagram och definitioner av variabler. Du får skriva på svenska eller engelska, men vi rekommenderar att diagram och ekvationer används i stället i de flesta fall.

KS2 ger inte direkt betyg, utan poäng som kan ersätta poängen i sektion-B i tentan (TEN1, mars) om KS:en gav mer. Se därför reglerna för TEN1 angående gränser.

1. Bestäm följande storheter:

- a) [2p] Energin lagrad i C_1 vid $t = 0^-$.
- b) [2p] Effekten in till R_2 vid $t = 0^+$.
- c) [1p] Effekten från källan U när $t \rightarrow \infty$.

2.

- [5p] Bestäm den markerade strömmen i , för $t > 0$.

The End. *Don't waste remaining time ... check your solutions!*

Solutions (EI1120 KS 2 VT21, 2021-02-17)

Q1.

The original circuit is shown on the right.

The only change over all time is the step function of the current source. This causes the current source to give current I for $t \leq 0$, and 0 for $t > 0$.

Our task is to determine some quantities in the equilibrium just before the step, then immediately after the step, and then in the new equilibrium a long time after the step.

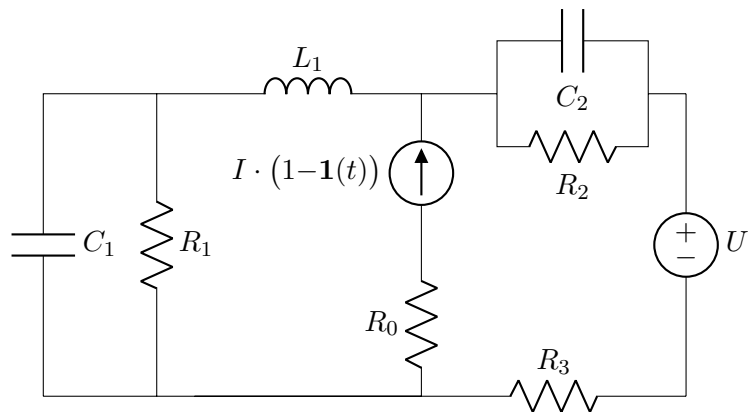

Initial Equilibrium: $t = 0^-$

The circuit at this time can be written with capacitors and inductors replaced with open and short circuits, and with the current source at its value for $t < 0$.

There are three parallel branches, if ignoring the open circuits.

The first task is to find the energy stored in C_1 at this time, which depends on the voltage u_{C1} .

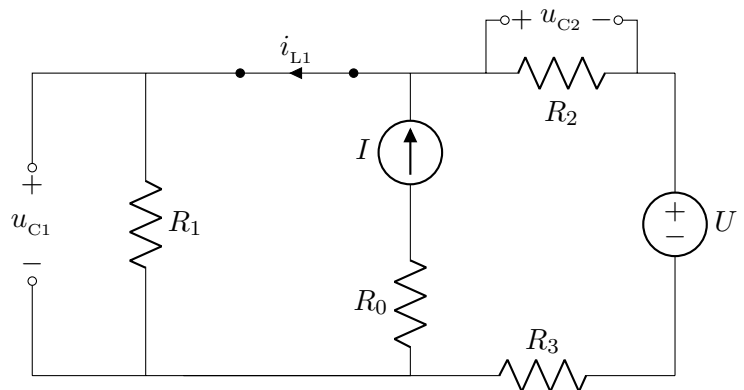

Good ways to find this voltage include KCL at the top node, source transformation or superposition. Let's try superposition.

With the current source active and the voltage source set to zero, the voltage $u_{C1(I)}$ is the voltage of I flowing in the parallel sum of R_1 and $R_2 + R_3$:

$$u_{C1(I)} = \frac{IR_1(R_2 + R_3)}{R_1 + R_2 + R_3}.$$

With the voltage source active and the current source set to zero, the current-source branch is like an open circuit so it can be ignored, leaving a single series loop of the voltage source and three resistors. The voltage $u_{C1(U)}$ is then found by voltage division, as the voltage across R_1 ,

$$u_{C1(U)} = \frac{UR_1}{R_1 + R_2 + R_3}.$$

The complete solution is the superposition of both sources' contributions:

$$u_{C1} = u_{C1(I)} + u_{C1(U)} = \frac{I(R_2 + R_3)R_1 + UR_1}{R_1 + R_2 + R_3}.$$

a) Energy stored in C_1 at $t = 0^-$: $\frac{1}{2}C \left(\frac{I(R_2 + R_3)R_1 + UR_1}{R_1 + R_2 + R_3} \right)^2.$

We could also try to find the other continuous quantities, i_{L1} and u_{C2} , which might be useful later for finding what happens at $t = 0^+$.

Now that we know the voltage u_{C_1} , we can use KVL to show that this is also across R_1 , then Ohm's law to find the current in R_1 , then KCL to show that this is the current in the inductor. The result is

$$i_{L_1}(0^-) = \frac{u_{C_1}}{R_1} = \frac{I(R_2 + R_3) + U}{R_1 + R_2 + R_3}.$$

It turns out that in fact this solution of $i_{L_1}(0^-)$ is not needed later ...

We also find that

$$u_{C_2}(0^-) = \frac{IR_1R_2 - UR_2}{R_1 + R_2 + R_3}.$$

This was found by superposition, quite similarly to the case for u_{C_1} but now looking at a different resistor.

Immediately after the change: $t = 0^+$

The resistor R_2 is in parallel with C_2 , so they have the same voltage. We know the voltage across C_2 at $t = 0^-$, and we know that a capacitor's voltage is a continuous quantity that won't change significantly in the instant of measuring.

The power into R_2 at $t = 0^+$ is therefore

$$P_{R_2} = \frac{u_{C_2}^2}{R_2} = \frac{1}{R_2} \left(\frac{IR_1R_2 - UR_2}{R_1 + R_2 + R_3} \right)^2,$$

or after some simplification,

b)
$$P_{R_2} = R_2 \left(\frac{IR_1 - U}{R_1 + R_2 + R_3} \right)^2.$$

A long time after the change: $t \rightarrow \infty$

Now the capacitors and inductors are in equilibrium, as at $t = 0^-$, and the current source is zero so its branch can be neglected.

There is just a loop of three resistors driven in series by the voltage source. The current out from the voltage source's + terminal is found by Ohm's law on the equivalent resistance,

$$i = \frac{U}{R_1 + R_2 + R_3}.$$

The product of this current and the voltage U is the power supplied by the source.

c) Power from source U as $t \rightarrow \infty$ is:

$$P_U(\infty) = \frac{U^2}{R_1 + R_2 + R_3}.$$

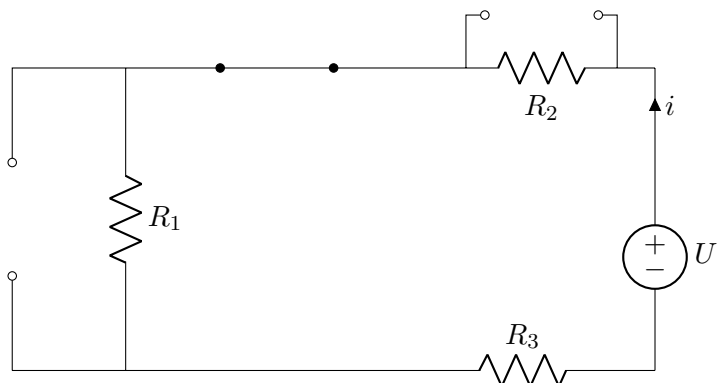
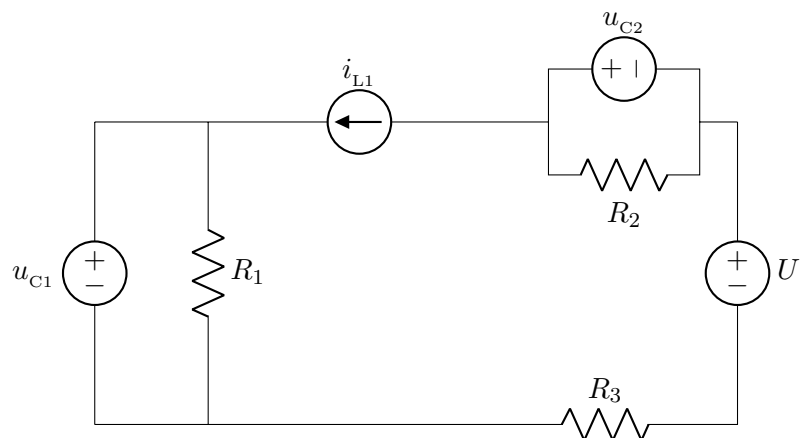

Q2.

The general circuit (for all times) is shown to the right.

Our task is to find the current marked i that flows in the capacitor, as a function of time, after the switch opens.

This requires some analysis of the state *before* the switch opens, in order to find the initial condition of the capacitor's voltage, which is the only 'memory' (energy-storing) in the circuit.

Then further analysis is needed of the state *after* the switch opens, to determine the differential equation that governs the circuit then, or the time-constant and final value.

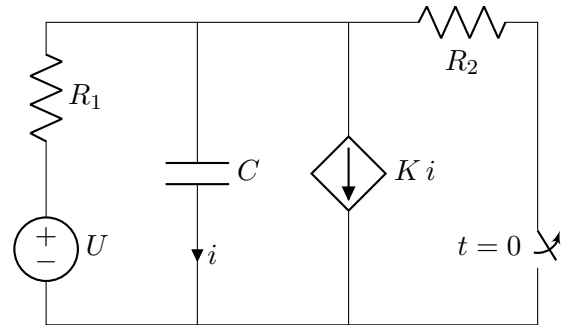

Before the change: $t = 0^-$.

In the initial state, $t < 0$, the switch is closed, so there are four parallel branches.

However, at the time before the switch changes we assume an equilibrium, as the circuit has been unchanged for a long time. The capacitor can therefore be treated as an open circuit. This means that $i = 0$ and therefore that this branch can be neglected. It also means that the branch of dependent source Ki can be neglected, as its current must also be zero.

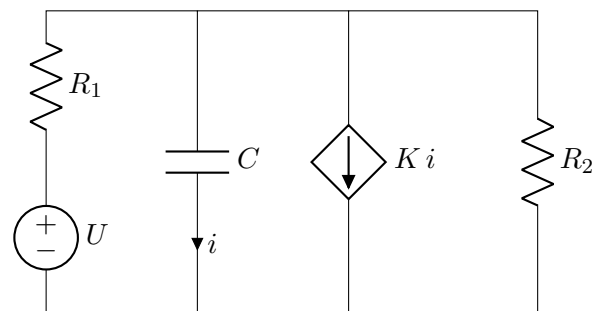

The circuit at $t = 0^-$ is therefore simplified to the one shown on the right. By voltage division,

$$u(0^-) = \frac{UR_2}{R_1 + R_2}.$$

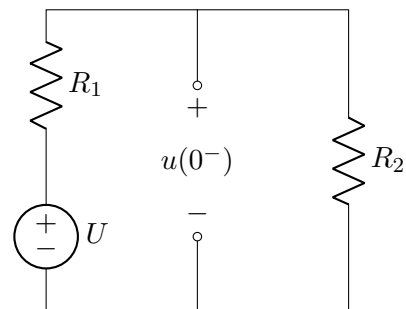

The time-span of interest: $t > 0$.

During the time of interest, $t > 0$, the open switch causes the fourth branch to become open-circuit, leading to the simplified form of the circuit shown here.

It is helpful to find the Thevenin equivalent between the terminals at which the capacitor connects, without the capacitor present.

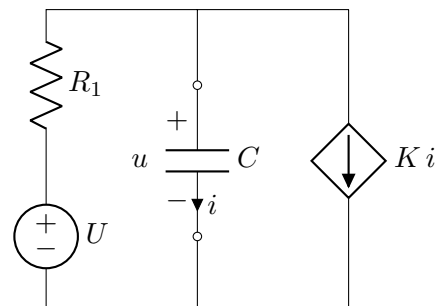

Voltage u can be found in terms of i by the following method:

- KCL above C shows that the current upwards in R_1 is $i + Ki$,
- Ohm's law in R_1 finds the voltage across R_1 to be $R_1(i + Ki)$,
- KVL around the left loop then gives the relation of u and i as:

$$u = U - (1 + K)R_1 i.$$

The relation of u and i for a Thevenin source is $u = U_T - i R_T$. Comparing this with the above relation for the circuit seen at the capacitor's terminals (without the capacitor present), we see that the circuit's Thevenin resistance is $R_T = (1 + K)R_1$ and its Thevenin voltage is $U_T = U$.

Solution possibilities

We are ultimately looking for $i(t)$, but we start by finding the function for the continuous variable $u(t)$.

The initial condition is known from the study of $t = 0^-$: continuity tells us that $u(0^+) = u(0^-)$.

The behaviour of the rest of the circuit at $t > 0$ is described by the relation of u and i shown above.

A solution for $u(t)$ could be found in several ways. Three possible ways are mentioned below, the last of which is used to find $u(t)$. Then $i(t)$ is derived from this.

I. FIND AND SOLVE ODE

Start from the relation $u = U - (1 + K)R_1 i$.

Note that u and i are across the capacitor, so are related by $i = C \frac{du}{dt}$; use this to substitute for i in the above equation, therefore giving a differential equation in u .

Solve this with the initial condition that was already found.

II. FIND AND SOLVE ODE FOR THEVENIN EQUIVALENT

If you already have a 'standard solution' in your memory, for a capacitor connected to a Thevenin equivalent of U_T and R_T , then you can use this.

III. FIT THE INITIAL AND FINAL VALUES AND TIME-CONSTANT BY A DECAYING EXPONENTIAL

The initial and final values and time-constant can be used to find the time function.

The initial value is $u(0^-) = \frac{UR_2}{R_1 + R_2}$.

The final value is $u(\infty) = U$, as U is, for $t > 0$, the Thevenin voltage at the terminals where the capacitor connects.

The time-constant is $\tau = CR_{\text{Thevenin}} = (1 + K)R_1 C$.

From these,

$$u(t) = u(\infty) + (u(0^-) - u(\infty)) e^{-t/\tau} = U + \left(\frac{UR_2}{R_1 + R_2} - U \right) e^{-\frac{t}{(1+K)R_1 C}} \quad (t > 0).$$

which can be simplified to

$$u(t) = U \left(1 - \frac{R_1}{R_1 + R_2} e^{-\frac{t}{(1+K)R_1 C}} \right) \quad (t > 0).$$

Finding the current.

It was actually the current that was to be found. Now that we have determined the continuous variable, we can find the current or other quantities from it.

By the relation for a capacitor,

$$i = C \frac{du}{dt} = C \frac{d}{dt} \left(U - \frac{UR_1}{R_1 + R_2} e^{-\frac{t}{(1+K)R_1 C}} \right) = C \frac{-1}{(1+K)R_1 C} \frac{-UR_1}{R_1 + R_2} e^{-\frac{t}{(1+K)R_1 C}}$$

This can be cleaned up to

$$i(t) = \frac{U}{(1+K)(R_1 + R_2)} e^{-\frac{t}{(1+K)R_1 C}} \quad (t > 0).$$